

## **The Research on Flexural Behavior Experiment of Pre-Stressed Glue-Lumber Beams after Long-Term Loading**

\*Guo Nan, \*\*Jiang Haixin, \*\*\* Zuo Hongliang

\* School of Civil Engineering, Northeast Forestry University  
China, Harbin in Heilongjiang Province ([snowguonan@163.com](mailto:snowguonan@163.com))

\*\* School of Civil Engineering, Northeast Forestry University  
China, Harbin in Heilongjiang Province ([2268139711@qq.com](mailto:2268139711@qq.com))

\*\*\* School of Civil Engineering, Northeast Forestry University  
China, Harbin in Heilongjiang Province ([zh19163@163.com](mailto:zh19163@163.com))

### **Abstract**

Due to the creep characteristic of wooden materials, long-term loading exerts great influence on the strength and stiffness of wooden crafts. Based on the experiment of long-term loading, this paper conducted comparative experiment on beams that were not long-term loaded, beams that were long-term loaded, and long-term loaded beams whose deformation was adjusted to the original size at the beginning of long-term loading through pre-stressing device. Results show that: pre-stress control can saliently improve the failure modes of beams; long-term loading decreased the ultimate load by 13%~39.34%, while pre-stress control increased the ultimate load by 12.23%~74.03%; long-term loading had little influence on beams stiffness, but decreased their deformation capacity by 39.47%~55.76%. Pre-stress control had little influence on beams deformation capacity, but remarkably improved their strength.

### **Key words**

Pre-stressed glue-lumber beams, performance under sustained loading, short-term flexural behavior, pre-stress control

### **1. Introduction**

Wood building has always been a kind of popular construction due to the safety and comfort of living. In recent years, under the global background of developing green construction, wood construction is given new development opportunities because it is environmentally friendly and

produces little carbon dioxide [1]-[3]. As the major supporting component of wood building, traditional glue-lumber still has some shortcomings. For example, its compressive strength cannot be brought into full play. It is prone to brittle failure and severe deformation. Therefore, a composite component of steel and wood with pre-stressed tendon being pulled and glue-lumber being compressed are put together to form pre-stressed glue-lumber beams [1]. This kind of beam is characterized by deformation-resistance, making full use of compressive strength of glue-lumber and plastic failure. However, after long-term loading, due to the creep characteristic of wood components, the strength and stiffness of wood components will both decrease remarkably. Some research showed that the strength of solid wood will decrease by 40% after 10 years' loading. Hence, it is of great significance to study the flexural behavior of pre-stressed glue-lumber beams after long-term loading.

Recently, research from home and abroad mainly focused on the creep deformation of wooden materials, components and structures [2-4], the mechanical performance of glue-lumber beams [5-7], and the relaxation of pre-stressed tendons [8-11], but the flexural behavior of glue-lumber beams after long-term loading were barely touched. And the influence of long-term loading on the mechanical performance of glue-lumber beams was remarkable, which should be considered during design stage. Therefore, it is necessary to conduct relevant research work.

In this paper, short-term loading experiment was conducted on pre-stressed glue-lumber beams after long-term loading. After a comparative analysis of beams that were not long-term loaded, beams that were long-term loaded, and long-term loaded beams whose deformation was adjusted to the original size at the beginning of long-term loading through pre-stressing device from the aspects of failure mode, bearing capacity and deformation, the thesis evaluated the influence of creep deformation on beams and clarified the controlling effect of pre-stressing device.

## **2. Overview of The Experiment**

### **2.1 Pre-stressing System**

The glue-lumber beam adopted in this experiment was pre-stressed through horizontal screw-thread straining equipment, as shown in Fig.1. This device consists of an arc-shaped deviator with a built-in groove, a screw, a steel shim and an anchor, etc. During the experiment, the pre-stressed steel wire was put through the anchor and got fixed. After anchoring the end, the pre-stressed steel wire was put in the groove of the deviator. The deviator can move downward through the rotating screw and create pre-stress.

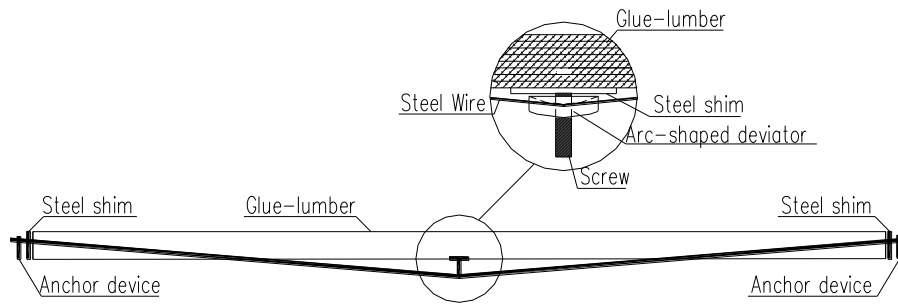

Fig.1. Pre-stressing system

## 2.2 Basic Information of Components

The experiment adopted glue-lumber beam, with a geometric reduced scale of 1:4, with its detailed size of 3150mm×100mm×100mm. The distance from beam-end to support was 75mm. Its illustration and the complete sketch after it was restructured on the field are shown in Fig.2, Fig.3.

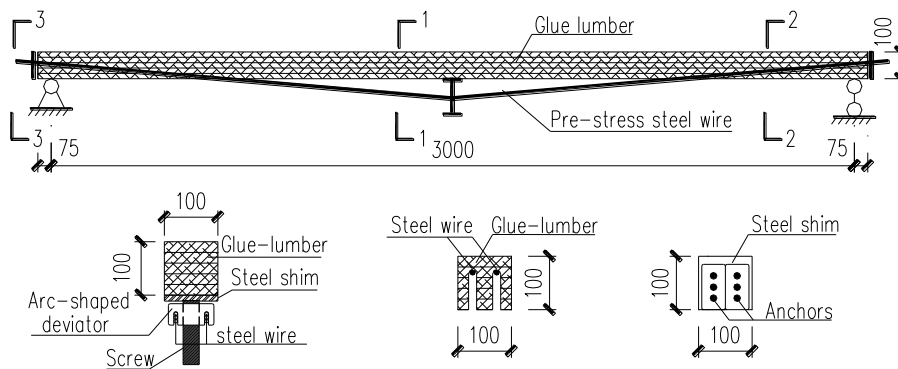

Fig.2. Diagrammatic sketch of pre-stressed glue-lumber beam (unit:mm)



Fig.3. Pre-stressed glue-lumber beam

## 2.3 Experiment Grouping

The short-term loading experiment conducted on pre-stressed glue-lumber beams is based on

the completion of long-term loading experiment. There are three groups for experiment: First group consists of 5 beams, and long-term loading experiment was directly followed by short-term loading experiment, without adjustment; Second group also consists of 5 beams, after long-term loading experiment, the deformation of beams was adjusted to the original size at the beginning of long-term loading through pre-stressing device, followed by short-term loading experiment; Third group consists of 15 beams, 3 beams in the same condition, and only short-term loading experiment was conducted. The specific beam numbers are shown in Table 1. In which, the corner mark X in  $L_{Xi-j}$  represents experiment group.

Table.1 Group information of beams

Groups	beam number					
1 <sup>st</sup> group	$L_{A1-2}$	$L_{A1-4}$	$L_{A1-6}$	$L_{A0-4}$	$L_{A1-4}$	$L_{A2-4}$
2 <sup>nd</sup> group	$L_{B1-2}$	$L_{B1-4}$	$L_{B1-6}$	$L_{B0-4}$	$L_{B1-4}$	$L_{B2-4}$
3 <sup>rd</sup> group	$L_{C1-2}$	$L_{C1-4}$	$L_{C1-6}$	$L_{C0-4}$	$L_{C1-4}$	$L_{C2-4}$

Note: when X is A, B, C, it refers to the first, second and third group respectively; i represents pre-stress level, when i is 0, 1, 2, it means that the total pre-stress is 0, 3.079kN, 6.158kN respectively; j represents steel wires number, when j is 2, 4, 6, it means that the number of steel wires is 2, 4, 6 respectively.

## 2.4 Loading Plan and Loading Mechanism

To conduct the counter-force of the support, a steel shim was put below the surface of beam-ends. Under the steel shims of the two beam-ends were a roller support and a fixed-shaft support. The beam was vertical to the support to meet the experiment requirement of forming simply supported beam.

The experiment was loaded at three dividing point. Before loading, a steel shim with a roller was put on both beam surface of three dividing point, and then the distribution beam was put on it. 6t jack was used to increase the loading grade by grade. When the load is less than  $50\%F$  ( $F$  is the estimated maximum external load), the load increases  $10\%F$  for every grade; when the load reaches  $50\%F$ , it is  $5\%F$  per grade; when the loading exceeds  $F$  while the beam still remains undamaged, the loading increases 1kN per grade until it is damaged.

To measure the deflection of beam-ends and the mid-span, two LVDTs with a range of 50mm was put in the support of each beam-end. Another LVDT with a range of 200mm was put in the mid-span. In order to momentarily monitor the stress change of glue-lumber beams and steel wires, five 100mm×3mm strain gauges were glued to each side of the mid-span. And two strain gauges of the same size were glued to the top of the mid-span. One 20mm×3mm strain gauge was glued to each steel wire. And a temperature compensation piece was glued to the glue-

lumber and the pre-stressed steel wire under the same experiment condition. The detailed position of the strain gauge is shown in Fig.4. During the process of loading, the deflection change of beam-ends and the mid-span, and the stress change of the pre-stressed steel wire and glue-lumber beams are simultaneously collected by multifunctional static-resistance strain gauge system of JM3813.



Fig.4. The illustration of strain gauge

### 3. Experimental Phenomena and Failure Modes

#### 3.1 Experimental Phenomena of First Group

During the preliminary stage of loading, the deflection of the beam displayed linear increase as the loading increased. After that, with the increase of loading, the deformation remarkably increased, and displayed elastic-plastic characteristics, as is shown in Fig.5. With the continuation of loading, clear cracking sound could be heard, but the surface of the beam did not display apparent cracks or damages; later when the loading further continued, the re-distribution of stress due to cracks in the preliminary stage helped stop the cracking and rendered the beam stable again; when the loading further increased by several grades, the beam gave out comparatively loud noise, with obvious cracks in interlaminates or at the beam bottom, as is shown in Fig.6.



Fig.5. Plastic deformation of the beam



(a) Failure mode of beam  $L_{A1-2}$



(b) Failure mode of beam  $L_{A1-4}$



(c) Failure mode of beam  $L_{A1-6}$



(d) Failure mode of beam  $L_{A2-4}$

Fig.6. Failure mode of the first group

The amount of loading that caused the beam to give out loud noise for the first time with obvious cracks is called obvious cracking load  $F_c$ . The obvious cracking load  $F_c$  of first group and its failure mode are shown in Table.2

Table.2 Data of first group

Number	$F_c/kN$	failure mode
L <sub>A1-2</sub>	5.90	tension failure of the third point shown in Fig.6(a)
L <sub>A1-4</sub>	8.21	tension failure of the third point shown in Fig.6(b)
L <sub>A1-6</sub>	13.23	Cracks in adhesive laminate causing tension failure of the beam bottom, shown in Fig.6(c)
L <sub>A0-4</sub>	5.65	Skew cracks in the laminate close to the beam bottom
L <sub>A1-4</sub>	8.21	tension failure of the third point shown in Fig.6(b)
L <sub>A2-4</sub>	15.69	Cracks in the knag of beam bottom causing penetrating cracks shown in Fig.6(d)

### 3.2 Experimental Phenomena of Second Group

Before loading, the pre-stress control was conducted, and the deformation of the mid-span of the beam was adjusted to the original size at the beginning of the long-term loading, as shown in Fig.7.



Fig.7. Pre-stress control of pre-stressed glue-lumber beam

The loading mechanism was same with first group. During loading process, the phenomena of second group are similar to first group. Failure modes of beams are shown in Fig.8.



(a) Wrinkles on the side surface of three dividing points



(b) Skew cracks on the surface of the beams

Fig.8. Failure modes of second group

The obvious cracking load  $F_c$  of second group and the failure modes are shown in Table.3.

Table.3 Data of second group

Number	$F_c$ /kN	failure mode
L <sub>B1-2</sub>	14.80	tension failure at the third point of the beam bottom
L <sub>B1-4</sub>	23.50	Wrinkles at the third point on the side surface of the beam shown in Fig.8(a)
L <sub>B1-6</sub>	29.80	Skew cracks on the top of the beams shown in Fig.8(b)
L <sub>B0-4</sub>	17.44	tension failure at the third point of the beam bottom
L <sub>B1-4</sub>	23.50	Wrinkles at the third point on the side surface of the beam shown in Fig.8(a)

Note: Beam L<sub>B2-4</sub> was damaged after the long-term loading experiment due to operational error, thus there is no data of the beam.

### 3.3 Phenomena of Third Group

Only short-term loading experiment was conducted on this group. The phenomena are similar to previous two groups, and the failure modes are shown in Fig.9.



(a) Glue failure of the laminate



(b) Tension failure of the beam bottom





(c) Tension failure of the beam top

Fig.9. Failure modes of third group

In this group, there are three beams for each number. The obvious cracking load  $F_c$  and the failure modes of each beam are shown in Table.4.

Table.4 Data of loading on third group

Number	$F_c$ /kN	failure mode
LC1-2	21.02	glue failure of one beam, shown in Fig.9(a) tension failure of two bottom fibers, as shown in Fig.9(b)
LC1-4	23.61	glue failure of one beam, shown in Fig.9(a) tension failure of one bottom fiber, shown in Fig.9(b) fiber damage on beam top under compression, as shown in Fig.9(c)
LC1-6	24.06	glue failure of one beam, shown in Fig.9(a) tension failure of one bottom fiber, shown in Fig.9(b) fiber damage on beam top under compression, shown in Fig.9(c)
LC0-4	18.24	glue failure of one beam, shown in Fig.9(a) tension failure of two bottom fibers, as shown in Fig.9(b)
LC1-4	23.61	glue failure of one beam, shown in Fig.9(a) tension failure of one bottom fiber, shown in Fig.9(b) fiber damage on beam top under compression, as shown in Fig.9(c)
LC2-4	23.00	fiber damages on beam top under compression, shown in Fig.9(c)

Note: the obvious cracking load  $M_c$  of each number is the average of thee beams of that particular number.

### 3.4 Analysis of Failure Modes

Fig.6, Fig.8 and Fig.9 show that the main failure modes of pre-stressed glue-lumber beams were: tension failure of bottom fibers, shown in Fig.6(a), (b) and 9(b); fiber damage on beam top under compression, shown in Fig.8(b), 9(c); glue failure of laminate or horizontal crack, shown in Fig.6(c), (d), 9(a).

After statistical analysis, failure mode of first group is mostly tension failure of bottom fibers, and the second group is mostly fiber damage on beam top under compression. This can be accounted for by the fact that the control on pre-stressed glue-lumber beams after long-term loading increased the stress of pre-stressed steel wire. According to the condition of cross-section

equilibrium, the pressure on the glue-lumber would definitely increase. Namely the compressive stress on the top of the glue-lumber increased and the pulling stress on the bottom decreased. The neural axis of the cross-section moved downward, as shown in Fig.10. Such stress change in the cross-section made it easier for tension failure of the beam top to happen.

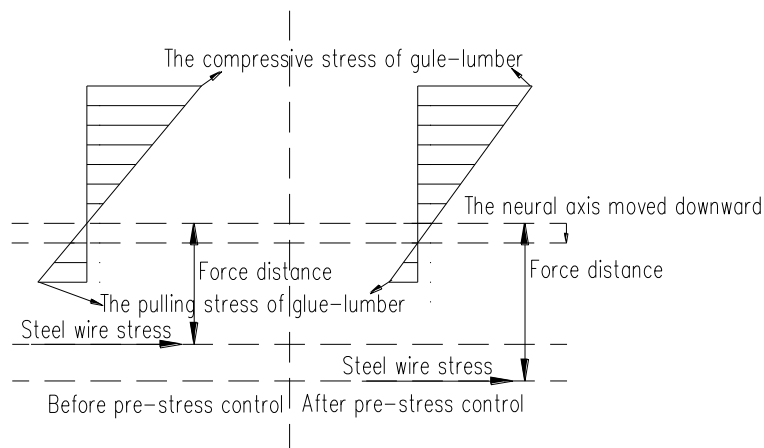

Fig.10. Analytical sketch of the stress on the front and back cross-section of pre-stress control

On the other hand, for beams with few pre-stressed steel wires or with low pre-stress value, tension failure of bottom fibers was easily occurred; for beams with more pre-stressed steel wires or with high pre-stress value, fiber damage on beam top under compression occurred frequently. This is because for beams with few pre-stressed steel wires or low pre-stress value, the position of the neural axis of cross-section of the beam was relatively higher and the pulling stress at the bottom bigger, making it easier for tension failure of bottom fibers to occur; Vice versa, for beams with many pre-stressed steel wires or with a high pre-stress value, the position of the neural axis was relatively lower, the compressive stress on the top bigger, making it easier for fiber damage on beam top under compression to occur. It should be noted that if there are obvious defects on beam, damage is bound to happen in places near the defect, changing the failure mode of beams. Therefore, the above conclusion is only fit for beams with relatively fewer defects.

## 4. Experimental results and analysis

### 4.1 Ultimate Load

A comparative analysis was carried out on beams after both long-term loading experiment and short-term loading experiment and beams after only short-term loading. Namely the ultimate loads  $F_u$  of first and third group were analyzed comparatively. Taken the ultimate load of third group as an standard, the percentage of ultimate load of first group in that of third group was calculated, as shown in Table 5.

Table.5 ultimate loads of First and third groups

The third set of beams		The first set of beams		percentage /%
beam number	$F_u$ /kN	beam number	$F_u$ /kN	
LC1-2	21.02	LA1-2	12.75	60.66
LC1-4	24.42	LA1-4	17.09	69.98
LC1-6	23.03	LA1-6	16.32	70.86
LC0-4	19.33	LA0-4	16.51	85.41
LC1-4	24.42	LA1-4	17.09	69.98
LC2-4	23.92	LA2-4	20.81	87.00

Table.5 shows that the ultimate load of pre-stressed glue-lumber beams after long-term loading experiment decreased, because the creep deformation reduced the effect of pre-stress, increasing the pulling stress of the beam bottom and making it easier for tension failure to occur. The pre-stress being the same, when the number of steel wires increased from 2 to 6, compared with beams that were not long-term loaded, the ultimate load of beams that were long-term loaded decreased by 29.14%~39.34%. The more the steel wires, the less the ultimate load decreased; the number of steel wires being the same, when the pre-stress increased from 0 to 6.158kN, compared with beams that were not long-term loaded, the ultimate load of beams that were long-term loaded decreased by 13%~30.02%.

A comparative analysis was carried out on beams after long-term loading experiment and deformation adjustment and beams after only short-term loading. Namely the ultimate loads  $F_u$  of second and third group were analyzed comparatively. Taken the ultimate load of third group as an standard, the percentage of the ultimate load of second group in that of third group was calculated, as shown in Table.6.

Table.6 ultimate loads of second and third groups

The third set of beams		the second set of beams		percentage %
beam number	$F_u$ /kN	beam number	$F_u$ /kN	
LC1-2	21.02	LB1-2	23.59	112.23
LC1-4	24.42	LB1-4	31.76	130.06
LC1-6	23.03	LB1-6	40.08	174.03
LC0-4	19.33	LB0-4	33.78	174.75
LC1-4	24.42	LB1-4	31.76	130.06

Table.6 shows that pre-stress control remarkably increased the ultimate load of beams. This is because compared with beams that were only short-term loaded, in order to adjust the

deformation of beams that were long-term loaded to the original size at the beginning of loading, more pre-stress was needed. The internal lever arm increased. On the other hand, the stress condition of the glue-lumber itself differed a lot from the stress condition where under external loading, the bottom was pulled and the top was compressed. More external loading was needed to lever the stress. The pre-stress being the same, when the number of steel wires increased from 2 to 6, compared with beams that were only short-term loaded, the ultimate load of beams that were long-term loaded and whose deformation was adjusted to the original size increased by 12.23%~74.03%; the number of steel wires being the same, when the pre-stress increased from 0 to 6.158kN, compared with beams that were only short-term loaded, the ultimate load of beams that were long-term loaded and whose deformation was adjusted to the original size increased by 30.06%~74.75%.

## 4.2 Load-deflection Curve

A load-deflection curve was formed for beams after both long-term loading experiment and short-term loading experiment and beams after only short-term loading, namely, the first and the third group, shown in Fig.11. For convenience of comparison, it is decreed that deformation downward is positive and deformation upward is negative; at beginning of the loading, the deformation of the mid-span is zero.

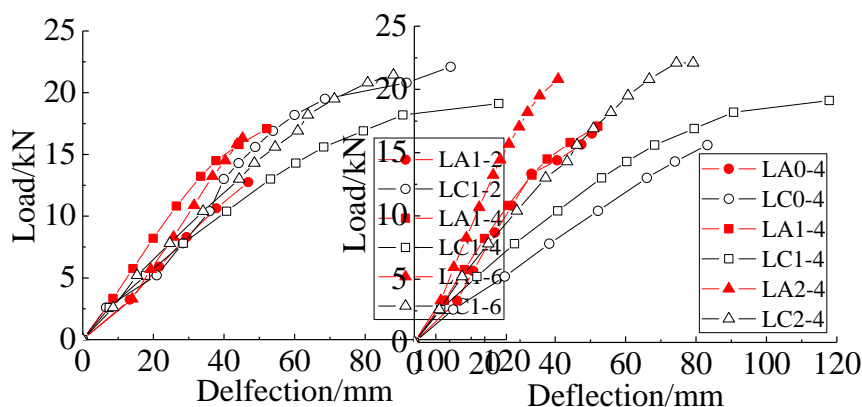

Fig.11. Load-deflection curves of first and third group

Fig.11 shows that the stiffness of beams that were long-term loaded was basically the same with that of beams that were not long-term loaded, but the beams deformation capacity decreased. The pre-stress being the same, but the number of pre-stressed steel wire being different, compared with beams that were not long-term loaded, the deformation from long-term loading that reached ultimate load decreased by 48.58%~55.76%; the number of steel wires being the

same, when the pre-stress increased from 0 to 6.158kN, the deformation from long-term loading that reached the ultimate load decreased by 39.47%~55.76%.

A load-deflection curve was formed for beams after both long-term loading experiment and deformation adjustment and beams after only short-term loading, namely, the second and third group, shown in Fig.12.

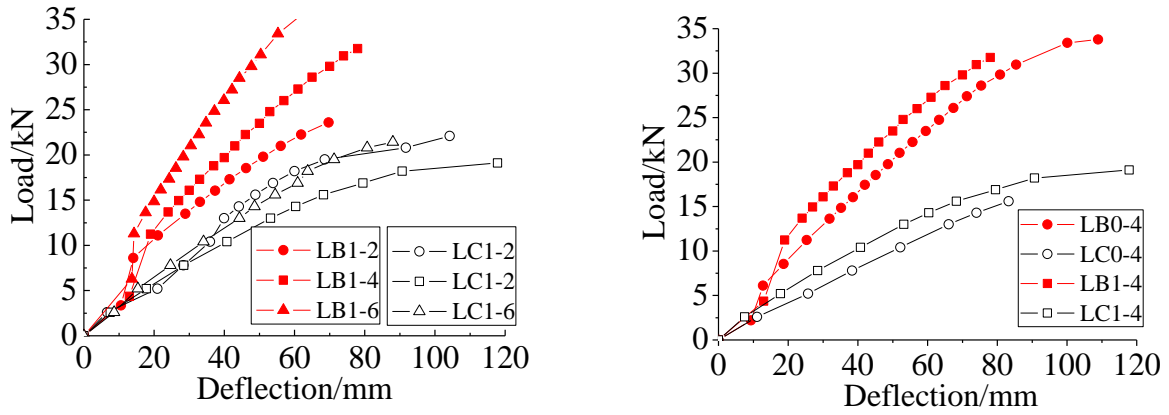

Fig.12. Load-deflection curves of second and third group

Fig.12 shows that the stiffness of beams that were long-term loaded and whose deformation was adjusted to the original size was remarkably bigger than those that were not long-term loaded since their internal lever arms increased, but their deformation capacity was basically the same.

## 5. Conclusion

(1) Compared with beams that were not long-term loaded, beams that were long-term loaded are prone to tension failure of the beam bottom, and beams after long-term loading and deformation adjustment are prone to tension failure of the beam top. Pre-stress control can remarkably improve the failure modes of beams.

(2) Compared with beams that were only short-term loaded, the ultimate load of beams that were long-term loaded decreased by 13%~39.34%; the ultimate load of beams after long-term loading and deformation adjustment increased by 12.23%~74.03%.

(3) The stiffness of beams that were long-term loaded was basically the same with that of beams that were not long-term loaded. But their deformation capacity decreased by approximately 39.47%~55.76%; the stiffness of beams after long-term loading and deformation adjustment was remarkably bigger than that of beams that were not long-term loaded, but their deformation capacity was basically the same.

## Acknowledgment

In the process, this project was supported by central funds in colleges and universities undergraduate course fee for special funds (2572015CB29), the funded project of China Scholarship Council (201606605044) and the project of state forestry administration science and technology research (2014-04).

## Reference

1. H.L Zuo, D.Y Wang, D.P He, Y.B Wang, Performances of Glued-laminated Timber in the Compressive Zone of Pre-stressed Glulam Beams, 2014, Journal of Northeast Forestry University, Vol.42, No.6, pp. 90-94,107.
2. T.Q Yang, W.B Luo, P. Xu, Y.T Wei, Q.G Gang, Viscoelasticity Theory and Application. China, 2004, Beijing: Science Press,
3. S. Thelandersson, J. H. Larsen, Timber Engineering. John Willey and Sons Ltd, 2003, pp.131-152.
4. Y.L Xu, Y.K Hua, Creep Behavior and Bending Properties of Poplar LVL in Different Assembly Types, 2002, China Wood Industry, Vol.16, No.6, pp.10-12.
5. F.R. Botros, Creep buckling of structures, 1983, AIAA Journal, pp. 237-251.
6. W.Q Liu, H.F Yang, Experimental Study On Flexural Behavior Of Engineered Wood Beams, 2008, Journal of Building Structures, Vol.29, No.1, pp. 90-95.
7. Alfredo S. Ribeiro, Abílio M.P. de Jesus, António M. Lima, José L.C. Lousada. Taheri, Study of strengthening solutions for glued-laminated wood beams of maritime pine wood, 2008, Construction and Building Materials, Vol.23, No.8, pp. 2738-2745.
8. W.C Xue, Performance of Pre-stressed Steel-Concrete Composite Beam under One-Year Sustained Loading, 2003, Bridge Construction, Vol.33, No.2, pp. 1-3, 15.
9. D.Y Wang, N Guo, J Hou, H.H Chen, Anti-compression Performance TestonBoard Agglutination Wood, 2014, Low Temperature Architecture Technology, Vol.36, No.2, pp.59-61.
10. X.Y Zhou, W.C Jin, S.L Li, Study on Calculation of Anchorage Loss of 3D Prestressing Tendons, 2008, Highway Engineering, Vol.33, No.5, pp.82-85.
11. L. Li, Creep Properties of Modern Glue Bamboo Material and Composite Structures, 2013, Hunan University, pp.32-36.