

Math function based controller applied to electric/hybrid electric vehicle

Raghavaiah Katuri^{1*}, Srinivasa R. Gorantla²

¹Electrical and Electronics Engineering, Research Scholar, Vignan's Foundation for Science, Technology and Research, Vadlamudi, Guntur, Andhra Pradesh 522213, India

²Electrical and Electronics Engineering, Professor, Vadlamudi, Guntur, Andhra Pradesh 522213, India

Corresponding Author Email: rk_eeep@vignanuniversity.org

Received: 3 January 2018

Accepted: 13 April 2018

Keywords:

Electric Vehicles (EV), Hybrid Electric Vehicles(HEV), Converters, Battery, Ultracapacitor (UC), Hybrid Energy Storage System (HESS), Math Function Based (MFB) Controller.

ABSTRACT

Hybrid Energy Storage System (HESS) has been implemented for better energy efficiency to Hybrid/Electric Vehicles (HEV/EV), in that the main source is battery and UltraCapacitor (UC) is the auxiliary source. Switching of the energy sources according to the electric vehicle speed also plays an important role, to improve the life of the battery. So designing of the controller is a dynamic factor in case of electric /hybrid electric vehicles. The main objective of this paper is to design a controller for the transition between the sources, battery and Ultracapacitor. Here controller has been designed based on the Math function coding and this can be termed as Math Function Based (MFB) Controller. The controller generates the signals to the converters based on the speed of the motor. The MFB controller mainly designed to work in four modes and for each and every mode separate math function has been created. The overall system has been simulated in MATLAB and plotted the all results with discussions.

1. INTRODUCTION

Day-to-day the demand for EV/HEV is increasing drastically due to several reasons like pollution in the atmosphere and for reducing the use of conventional fuel resource. Generally, all vehicles are driven by IC engines only and this needs petrol/diesel for its successful operation. These traditional IC engine vehicles are not eco-friendly in nature [1-5]. All above reasons for using IC engine is demanding an alternative for transportation purpose. At starting, scientists have replaced conventional sources with fuel cells and batteries to protect the environment and for a better transportation facility. But this attempt hasn't given expected results and is a grief to some hindrances like driving range limit [6-10]. For improving the performance of an electric vehicle, battery or fuel cell has been combined with UC. Batteries are having high energy density and low power densities on the other hand UC are having lower energy density and high-power density.

Based on Karush-Kuhn-Tucker conditions the real-time controller has been developed for HESS [1], a neural network-based strategy is implemented as an intelligent controller and an adaptive energy management control with an integrated variable rate-limit function is described for an energy storage system [2] and also using fuzzy logic.

By combining battery and UC forms a new energy source termed as HESS [10]. With this HESS vehicle gives better performance than a single source and it improves the state of charge of the battery [6]. In case of HESS, switching between the sources is very important [8-9]. Because according to the vehicle dynamics only the transition between two sources should be done and that will be accurate and quick. That means switching of sources plays a key role in vehicle performance that is the reason why in this work mostly

concentrated on the designing of a controller for good transition between the sources. Here MFB controller has been designed for the proper transition between two sources and this controller works depending upon the speed range of the motor. This MFB controller operated for four modes of operation of the motor and these four modes are categorized based on the speed value only.

2. PROPOSED MODEL

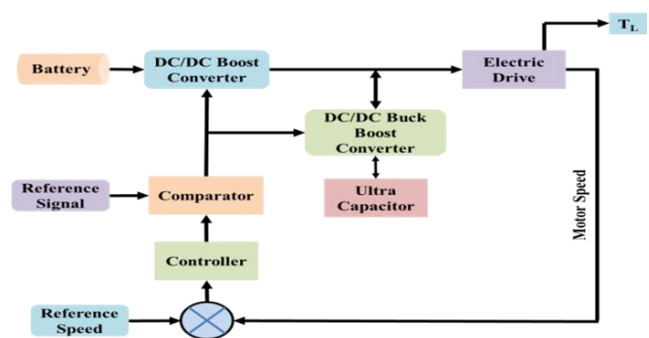

Figure 1. Proposed block diagram model for hybrid energy storage system

Above block diagram represents the proposed model of the work. In this, two sources are combined, giving energy to the electric motor to propel the vehicle [5]. Generally, the battery is the main storage system and it is capable to serve the required average power to the electric motor. The ultracapacitor is capable of giving the energy during transient periods of the electric motor [4]. Combination of the two sources gives good results for Electric Vehicles/Hybrid

Electric Vehicles. Here controller can generate the required pulses to the converters based on the speed tracking of the motor.

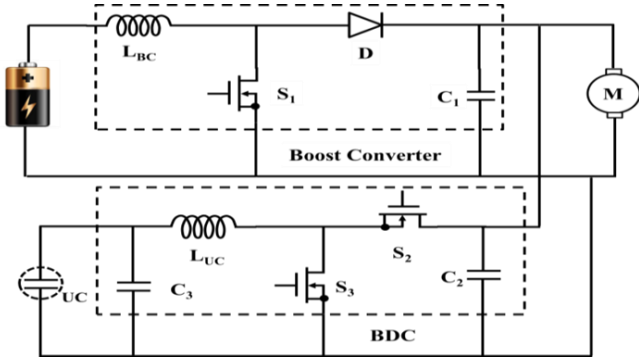

Figure 2. Converter main circuit diagram with HESS

Above Figure represents the converter model of hybrid energy storage system. Here Buck and Buck/Boost (BDC) converter model has been preferred with MOSFET switches. One of the converters is connected to the battery end and another converter is connected at UC end. UC end connected converter is a BDC and battery end connected is UDC. During peak power requirements of the motor, BDC acts as a Boost converter remaining cases it acts as Buck converter for charging from the battery that means UC is mending for only to reduce the extra burden on the battery during the transient conditions [7]. The battery is preferred here to supply the average power to the motor and it always in the on condition except some extreme conditions like during cold starting conditions. To achieve preferable control of energy storage system overall circuit can be resolved into four sub-circuits.

3. MODES OF OPERATION

The switches used in the HESS can operate based on the road conditions of the vehicle. The modeled circuit contains three controlled switches, and that can be operated in four modes. These four modes illustrated with switching action of three switches from below table.

Table 1. Load condition based switching action.

Mode	S ₁	S ₂	S ₃	Load Torque
I	OFF	OFF	ON	Heavy Load
II	ON	OFF	ON	Medium Load
III	ON	OFF	OFF	Rated load
IV	ON	ON	OFF	No Load

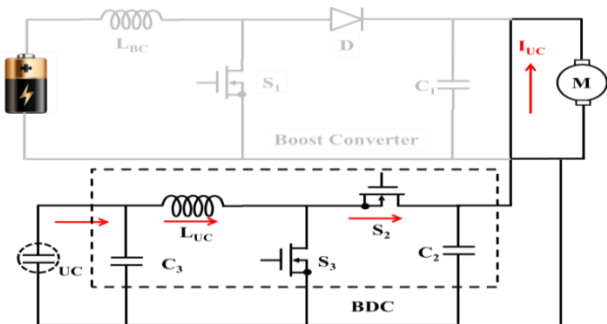

Figure 3(a). Converter mode-1 circuit diagram with HESS

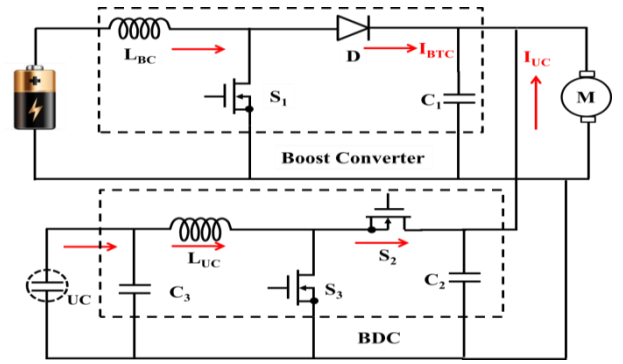

Figure 3(b). Converter mode-2 circuit diagram with HESS

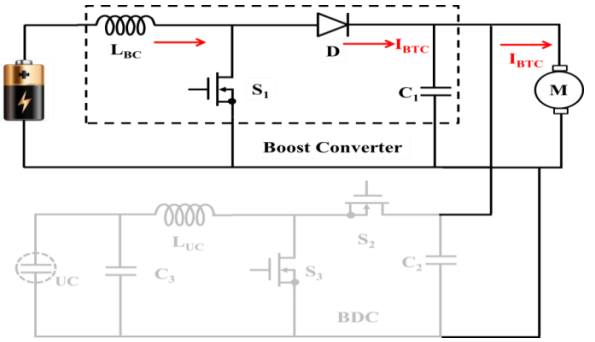

Figure 3(c). Converter mode-3 circuit diagram with HESS

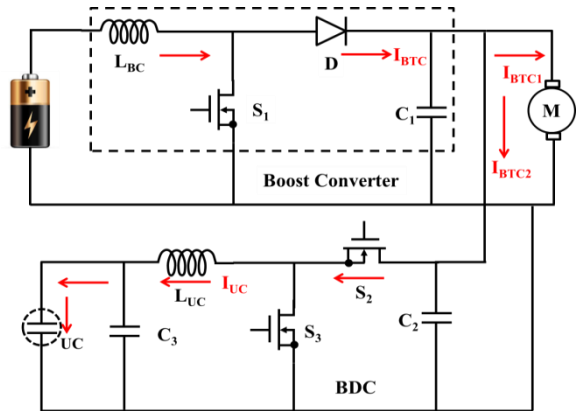

Figure 3(d). Converter mode-4 circuit diagram with HESS.

3.1 Mode-1 operation

Mode-1 is related to the heavy load on the motor, switch S₃ only operates and remaining switches S₁, S₂ are in OFF position. Total power flows from battery to motor through switch S₃. So in this mode of operation Bi-Directional Converter (BDC) acts as a boost converter and this converter operation controlled by the pulse signals, generated by the controller based on the speed of the electric motor.

3.2 Mode-2 operation

Mode-2 is related to the medium load on the motor switches S₁, S₃ operates and remaining switch S₂ is in OFF position. Power flows between battery to motor and UC to a motor that means BDC acts as a boost converter which is connected to ultracapacitor. In the same way battery is connected through UDC and this also supplies power to the motor. Finally, UC and battery combination supplies power to the electric motor.

3.3 Mode-3 operation

When the load on the motor is rated then Mode-3 can be used. In this mode of the operation switch, S_1 is only closed and remaining two switches are in open mode condition. That means entire energy required by the motor can be supplied by the battery and pulses generated by the controller to Uni-Directional Converter (UDC) only. So there are no pulse signals generated by the controller to BDC.

3.4 Mode-4 operation

In this mode of operation the switches S_1, S_2 are in closed position and remained to switch S_3 is in off position. During this mode of operation motor running under no load condition, so battery can supply energy to the motor as well UC for its charging purpose. Here BDC worked in buck mode.

4. CONTROL STRATEGY APPROACH

The motor rotates at the expected speed and has a certain amount of power request. As for the battery, it only works in a specific area to guarantee the optimum efficiency. If battery output power matches the requirement of the motor, the battery will be the only source to supply the loads. If there is a difference between battery supply and the motor demand, the UC will fill in the gap. It can be categorized into four modes of operation.

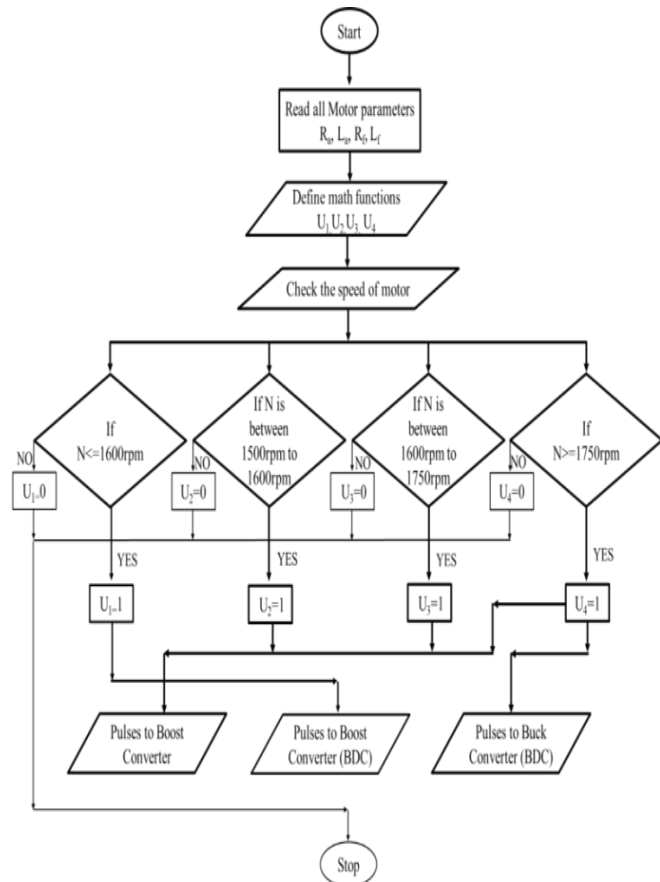

Figure 4. Flowchart for control strategy

(1) During starting of a motor and heavily loaded condition UC supply the power to the load. In this mode, the math

function U_1 gives signal value 1 and remaining all math functions generates signal 0 because during this period the speed of the motor ≤ 1600 rpm. The converter operates based on all math function generated signals. The converters in operation are the boost converter at the UC end.

(2) When the power demanded by the load is beyond the designed range of the battery output power, UC will assist the battery to deliver power to the motor. In this mode of operation, motor speed is from 1500 rpm to 1600 rpm. Hence MFB generates U_1 and U_2 pulse signals as 1 and generates U_3 and U_4 pulse signals as 0. The converters in operation are the boost converter at the battery end and the boost converter at the UC end.

(3) When battery output power matches the desired power of the motor, the battery will only supply the power to the motor. In this mode of operation, the speed of the motor is from 1600 rpm to 1750 rpm. Hence MFB generates U_2 and U_3 pulse signals as 1 and generates U_1 and U_4 pulse signals as 0. At this time, only the boost converter at the battery terminal works.

(4) When battery provides more power than the motor need, the extra power will be used to charge the UC. So the power of the battery will flow into both the UC and the motor. In this mode of operation, motor speed is >1750 rpm. Hence MFB generates U_2, U_3 and U_4 pulse signal as 1 and generates U_1 pulse signals as 0. According to the converters designed, the boost converter at the battery end and the buck converter at the UC end will work in this scenario.

5. SIMULATION RESULTS AND DISCUSSIONS

5.1 Mode-1 results

In this mode of operation, the motor has been working under overloaded condition according to the MFB controller UC can only supply the demand of motor. The load on the motor has been applied at 3sec. This variation has been clearly identified from the pulses given to the BDC (Boost mode) only, and there is no pulse signal to the UDC which is connected to the battery. During this period motor draws a current of 12A; the settled speed at of 860 rpm and Electrical torque is 14.25 N-m.

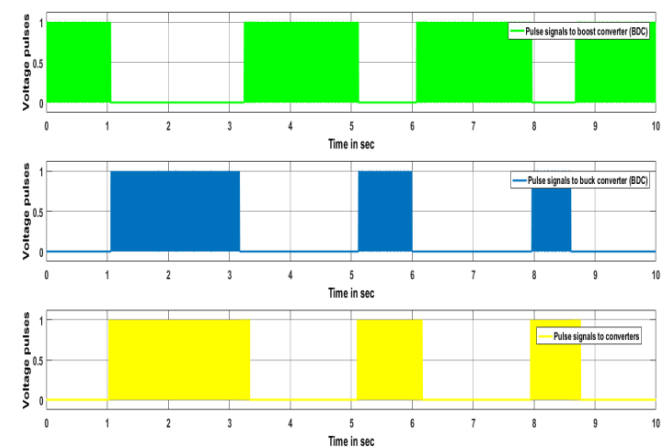

Figure 5(a). The pulse generated by the controller to UDC and BDC converters

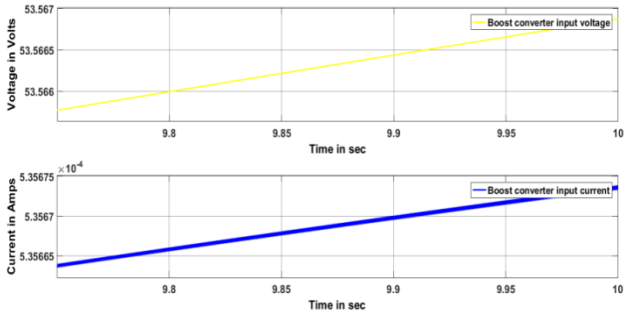

Figure 5(b). UDC input voltage and current

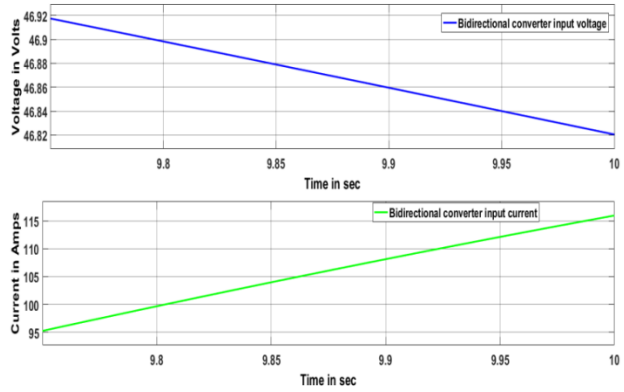

Figure 5(c). BDC input voltage and current

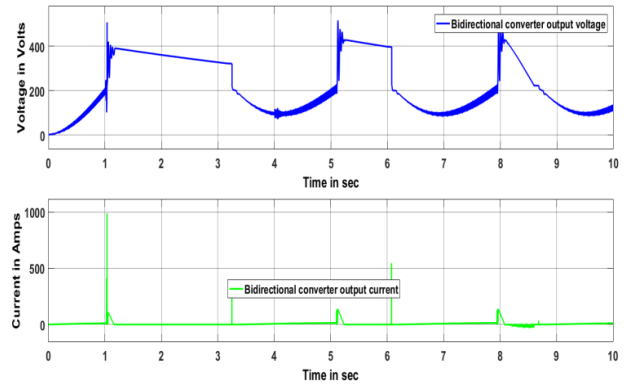

Figure 5(d). BDC output voltage and current

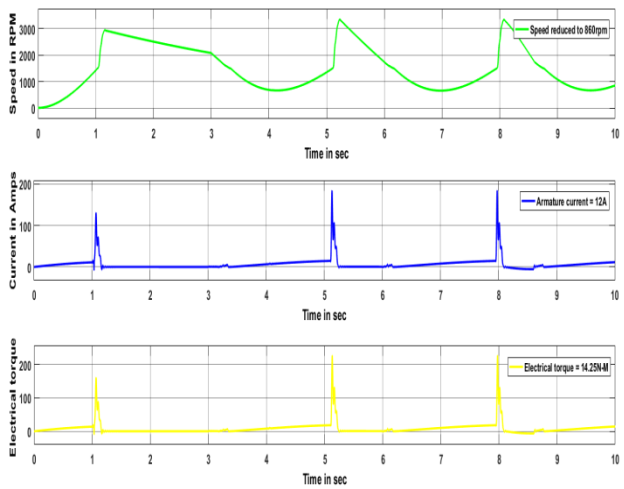

Figure 5(e). Motor output parameters (Speed, armature current, and electrical torque)

5.2 Mode-2 results

This mode represents that, the load on the motor is slightly more than its rated value. Battery supplies energy to the motor along with the UC in order to meet the overload capacity and these variations can clearly observe from the pulse signal waveform. The electrical torque 7.66 N-m, armature current 6.17A, and the speed reduced to 1521 rpm and settled at 1815 rpm.

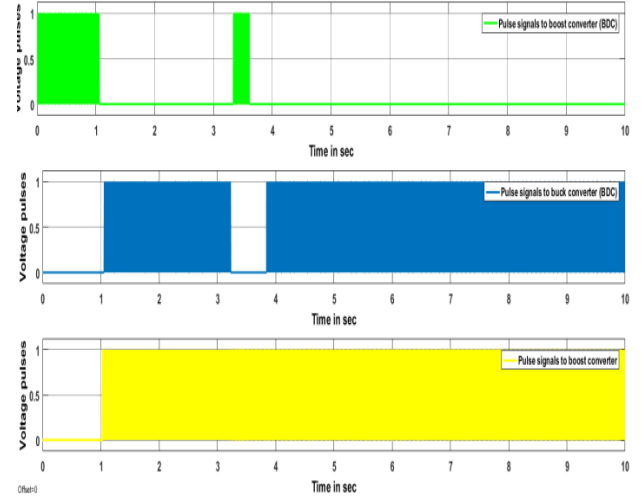

Figure 6(a). The pulse generated by the controller to UDC and BDC converters

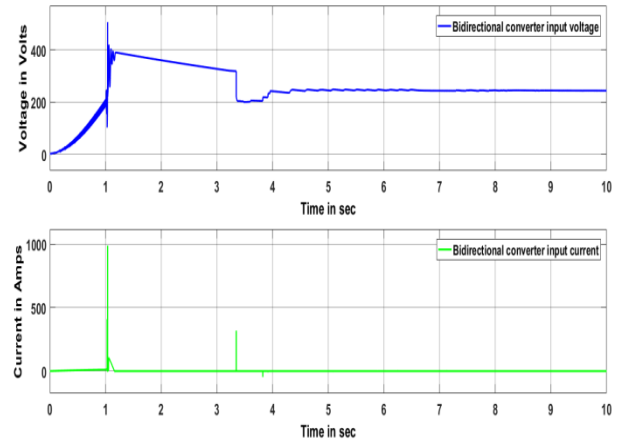

Figure 6(b). BDC input voltage and current

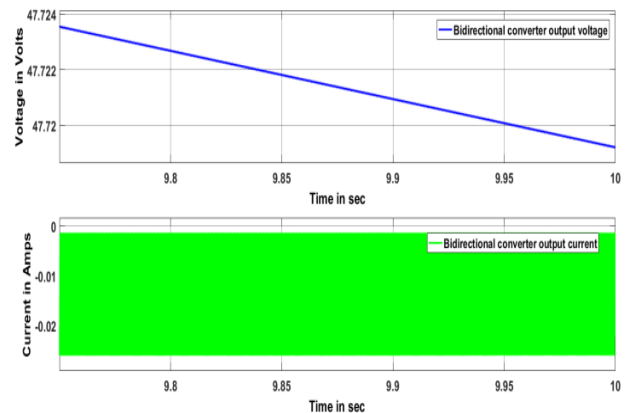

Figure 6(c). BDC output voltage and current

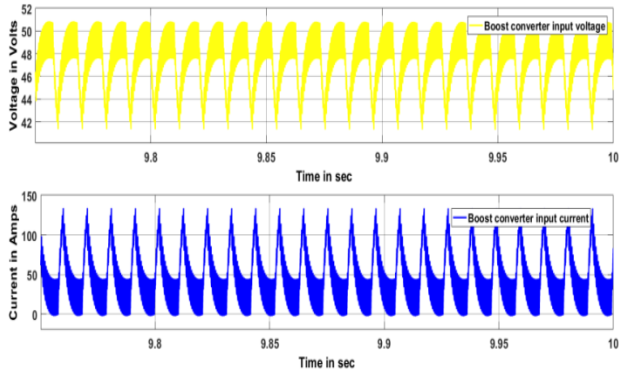

Figure 6(d). UDC input voltage and current

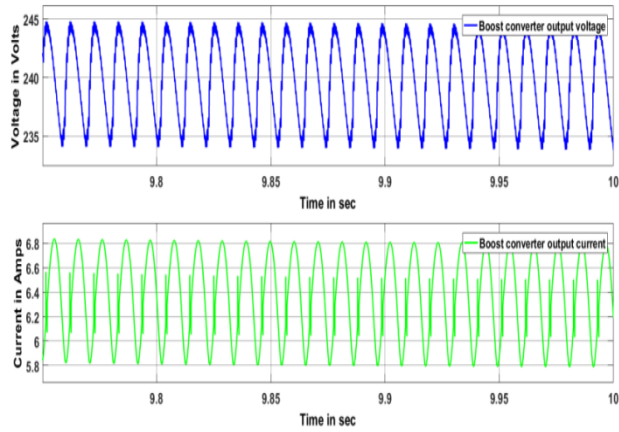

Figure 6(e). UDC output voltage and current

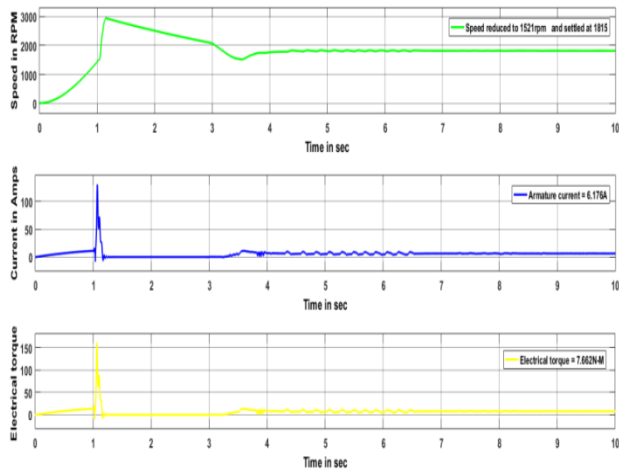

Figure 6(f). Motor output parameters (Speed, armature current, and electrical torque)

5.3 Mode-3 results

In this mode, the motor has worked with a rated load only, so the power draws by the motor is only from the battery and no need of BDC operation that is no supply requires from the UC. These changes can clearly notice from the pulse signals generated by the controller to the BDC and boost UDC. The electrical torque 4.42N-m, armature current 3.588A, and the speed reduced to 1630 rpm and settled at 1855 rpm.

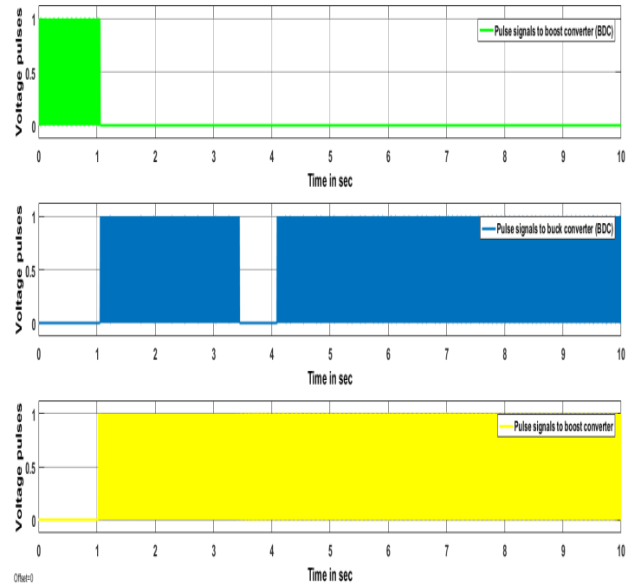

Figure 7(a). The pulse generated by the controller to UDC and BDC converters

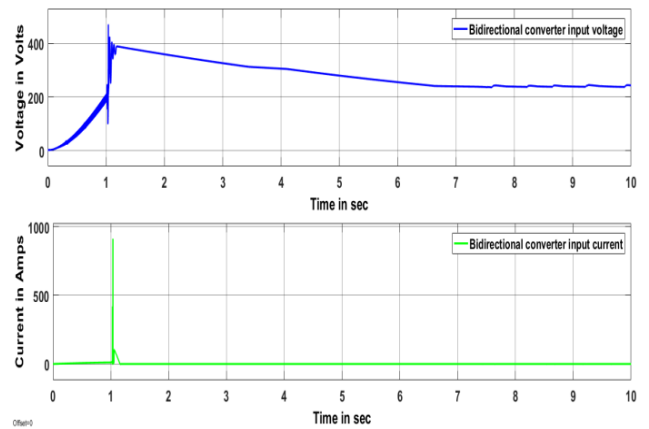

Figure 7(b). BDC input voltage and current

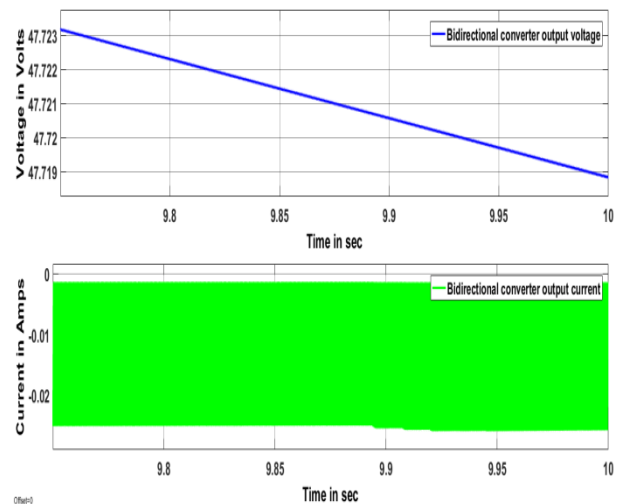

Figure 7(c). BDC output voltage and current

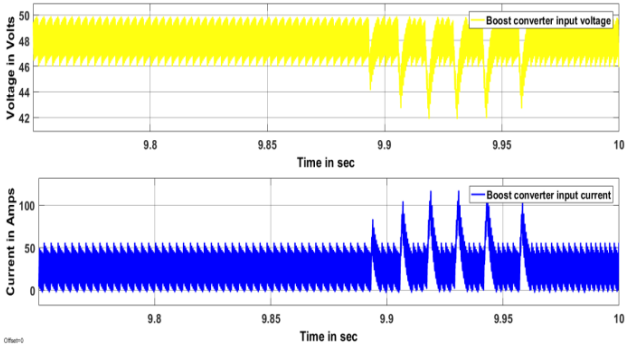

Figure 7(d). UDC input voltage and current

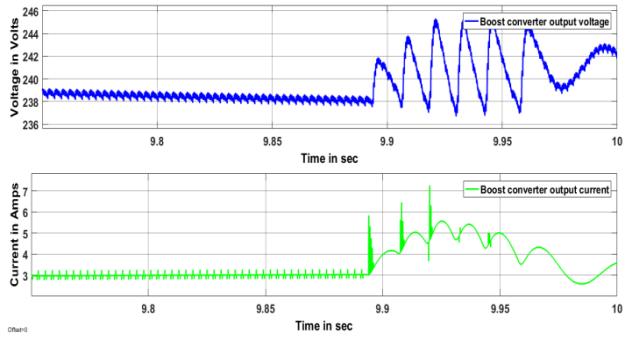

Figure 7(e). UDC output voltage and current

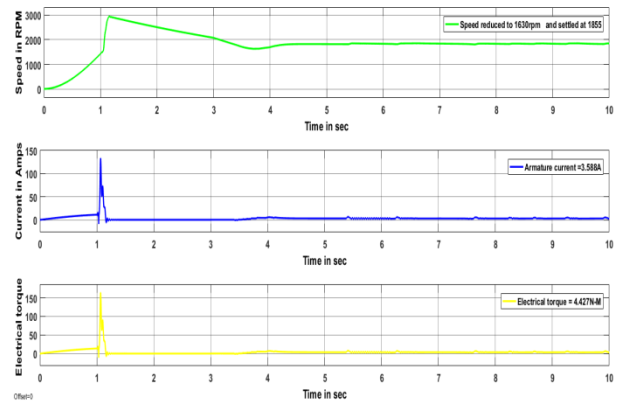

Figure 7(f). Motor output parameters (Speed, armature current, and electrical torque)

5.4 Mode-4 results

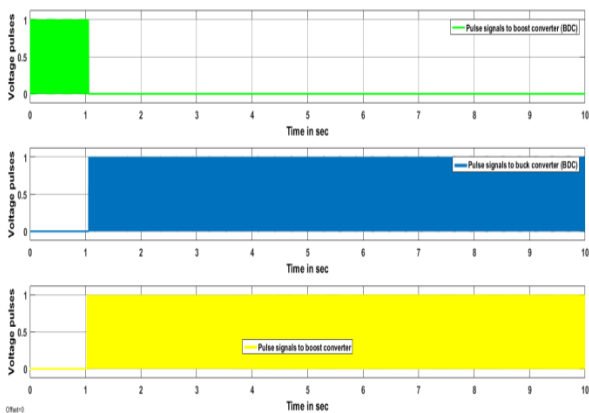

Figure 8(a). The pulse generated by the controller to UDC and BDC converters

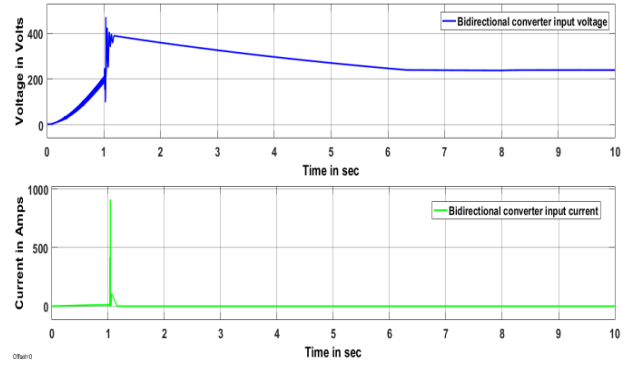

Figure 8(b). BDC input voltage and current

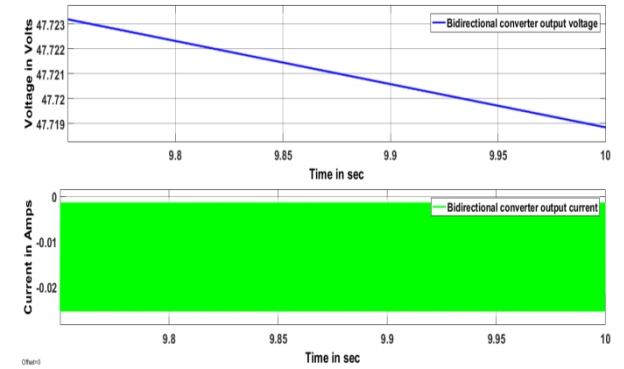

Figure 8(c). BDC output voltage and current

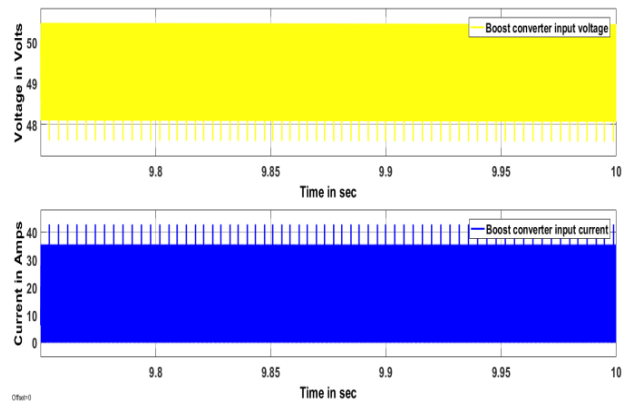

Figure 8(d). UDC input voltage and current

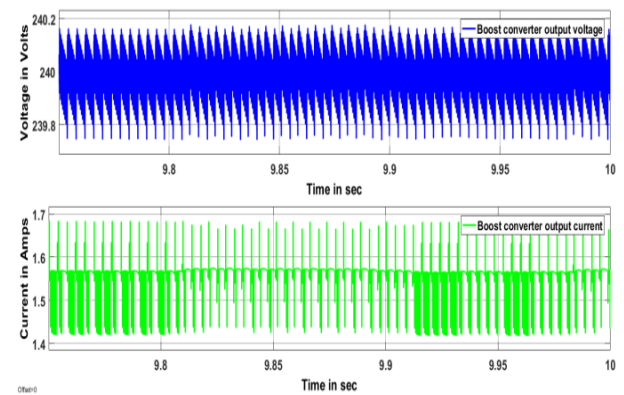

Figure 8(e). UDC output voltage and current

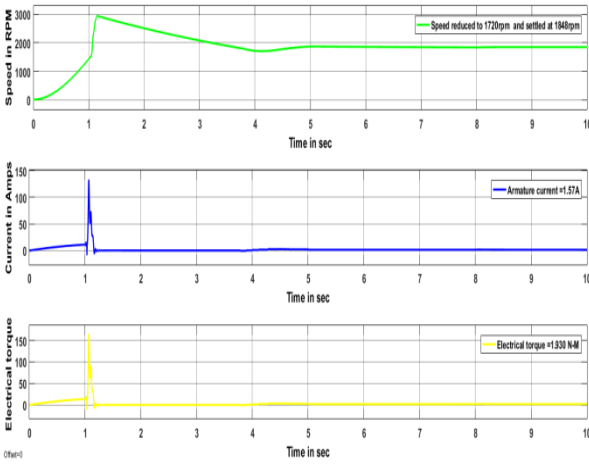

Figure 8(f). Motor output parameters (Speed, armature current, and electrical torque)

In this mode motor has worked under no load during this period motor requires less amount of power only so during this period battery supply energy to the motor and also UC. That means in BDC pulse signal has been generated for buck mode only and UDC pulses also generated which is connected to the battery. The electrical torque 1.90Nm, armature current 1.57A, and the speed reduced to 1720 rpm and settled at 1848 rpm.

6. CONCLUSION

The designed MFB controller reacted quickly to the corresponding speed of the motor. During heavy load condition, MFB controller generated a pulse signal as 1 to U_1 ; this signal initiated the operation of BDC as a Boost converter at UC end. During more than rated load condition MFB controller generate a pulse signal as 1 to U_1 and U_2 , this combination starts the operation of the Boost converter at Battery end and also BDC as a Boost converter at UC end. During rated load condition MFB generated a pulse signal as 1 to U_2 U_3 , this combination made to operate in only Boost converter at the Battery end. During no-load operation of the motor, MFB generated a pulse signal as 1 to U_4 and U_1 ; this made the operation of Boost converter at battery end and BDC as a Buck converter at UC end.

REFERENCES

- [1] Shen J, Khaligh A. (2016). Design and real-time controller implementation for a battery ultracapacitor hybrid energy storage system. *IEEE Transactions on Industrial Informatics* 12(5): 1910-8.
- [2] Wu D, Todd R, Forsyth AJ. (2015). Adaptive rate-limit control for energy storage systems. *IEEE Transactions on Industrial Electronics* 62(7): 4231-40.
- [3] Xiang C, Wang Y, Hu S, Wang W. (2014). A new topology and control strategy for a hybrid battery-ultracapacitor energy storage system. *Energies* 7(5): 2874-96.
- [4] Cao J, Emadi A. (2012). A new battery/ultracapacitor hybrid energy storage system for electric, hybrid, and plug-in hybrid electric vehicles. *IEEE Transactions on power electronics* 27(1): 122-32.
- [5] Khaligh A, Li Z, Battery. (2010). Ultracapacitor, fuel cell, and hybrid energy storage systems for electric, hybrid electric, fuel cell, and plug-in hybrid electric vehicles: State of the art. *IEEE Transactions on Vehicular Technology* 59(6): 2806-14.
- [6] Carter R, Cruden A, Hall PJ. (2012). Optimizing for efficiency or battery life in a battery/supercapacitor electric vehicle. *IEEE Transactions on Vehicular Technology* 61(4): 1526-33.
- [7] Golchoubian P, Azad NL. (2017). Real-time nonlinear model predictive control of a battery-supercapacitor hybrid energy storage system in electric vehicles. *IEEE Transactions on Vehicular Technology* 66(11): 9678-88.
- [8] Shen J, Khaligh A. (2015). A supervisory energy management control strategy in a battery/ultracapacitor hybrid energy storage system. *IEEE Transactions on Transportation Electrification* 1(3): 223-31.
- [9] Choi ME, Kim SW, Seo SW. (2012). Energy management optimization in a battery/supercapacitor hybrid energy storage system. *IEEE Transactions on Smart Grid* 3(1): 463-72.
- [10] Cao J, Emadi A. (2012). A new battery/ultracapacitor hybrid energy storage system for electric, hybrid, and plug-in hybrid electric vehicles. *IEEE Transactions on Power Electronics* 27(1): 122-32.